

STEEL PARTS

ITEM NO.	PART NO.	DESCRIPTION	QTY.
1	TLB318H	18' Heavy Bridge Grp Strut Design	1
2	BTPC-01	Bridge To Pipe Column Connection Plate	6
3	PC400-80-252	4" Sch. 80 x 21' Pipe Columns	6
4*	PC400	4" Sch. 80 Pipe Cap	6

HARDWARE

ITEM NO.	PART NO.	DESCRIPTION	QTY.
1	UB50X525	1/2" x 5-1/4" c-c x 6-1/2" isl A-36 U-Bolts	12
2	UB50X425SQ	1/2" x 4-1/4" c-c x 5-1/2" isl A-36 Sq. U-Bolts	12
3	NU05OG	1/2" H.D.G. Nuts	48
4	WL05OG	1/2" H.D.G. Lockwashers	48
5	WF05OG	1/2" H.D.G. Flatwashers	48

** Flatwashers Are To Be Used At All Slotted Hole Locations !! **

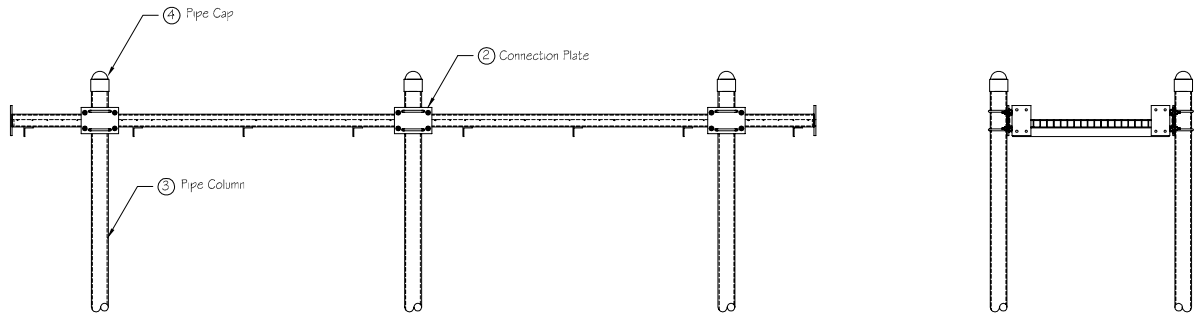

ASSEMBLY DRAWING

WEIGHT & ENGINEERING INFORMATION

KIT NO.	WEIGHT (lbs.)	DESCRIPTION	CaAc (Sq. Ft.)
KHB6-318-210-02	3260	3'-9" x 18' Bridge : Six 21' Columns	N/A

Connections 1 & 2

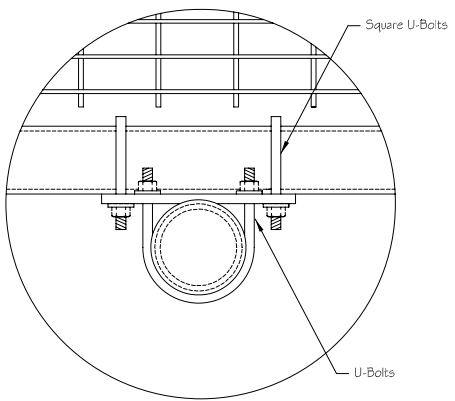

Foundation Detail

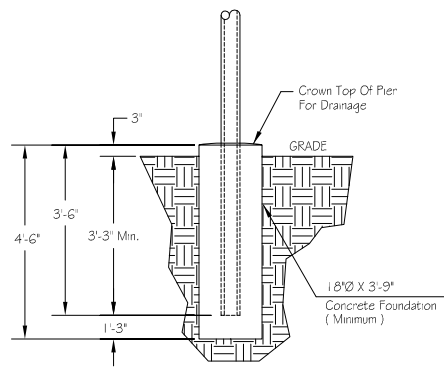

NOTES:

- Transmission Line Hangers Are Not Provided With This Kit !
- Steel Parts Indicated Above With An "*" Will Be Packed With The Hardware.
- The Foundation Design Provided Is Per Normal Soil Parameters Set Forth In TIA/EIA Standards. Bottom Of Foundation Must Be Extended Below The Frost Line For The Area In Which It Is To Be Installed. If Poor Soil Is Encountered, It Is Recommended That A Geotechnical Investigation Be Completed And Foundations Should Be Designed According To The Results & Recommendations Of The Geotechnical Report.

Tower Innovations

PH# (812) 853-0595
 FAX# (812) 853-6652
 2855 HIGHWAY 261
 NEWBURGH, IN. 47630

TITLE
 3'-9" X 18' BRIDGE WITH SIX 21' LENGTH PIPE COLUMNS

DWG NO.
 KHB6-318-210-02

REV
 -

DO NOT SCALE DRAWING

REV. #	DESCRIPTION	DATE	APP.	DRAWN A.J.H.	DATE 10-4-05

THIRD ANGLE PROJECTION

COMPANY CONFIDENTIAL INFORMATION CONTAINED HEREIN IS CONFIDENTIAL. IT IS TO BE USED SOLELY FOR THE PURPOSE PROVIDED, AND IT IS NOT TO BE DISCLOSED TO OTHERS WITHOUT THE PRIOR WRITTEN CONSENT OF TOWER INNOVATIONS

TOLERANCES

.X± 3/32" ANGLES± 2°
 .XX± 3/32" DRILLED HOLE± #1/32"
 .XXX± 1/16" BURNED HOLE± #1/16"

UNLESS OTHERWISE SPECIFIED DIMENSIONS ARE IN:
 INCHES