

ASSEMBLY DRAWING

Anchor Bolt Detail

STEEL PARTS

ITEM NO.	PART NO.	DESCRIPTION	QTY.
1	TLB312H	12' Heavy Bridge Gnp Strut Design	1
2	BTPC-01	Bridge To Pipe Column Connection Plate	4
3	HPLP-210	4" Sch. 80 x 21' Pipe Columns With Bottom Flange	4
4*	PC400	4" Sch. 80 Pipe Cap	4
5*	HTB-TEMP-01	Template For Anchor Bolts	4

HARDWARE

ITEM NO.	PART NO.	DESCRIPTION	QTY.
1	UB50X525G	1/2" x 5-1/4" c-c x 6-1/2" isl A-36 U-Bolts	8
2	UB50X4255Q	1/2" x 4-1/4" c-c x 5-1/2" isl A-36 Sq. U-Bolts	8
3	NU050G	1/2" H.D.G. Nuts	32
4	WL050G	1/2" H.D.G. Lockwashers	32
5	WF050G	1/2" H.D.G. Flatwashers	32
6	AB087X45	7/8" x 45" ASTM A-449 Anchor Bolts	24
7	NU087G	7/8" H.D.G. Nuts	72
8	WL087G	7/8" H.D.G. Lockwashers	24

** Flatwashers Are To Be Used At All Slotted Hole Locations !! **

WEIGHT & ENGINEERING INFORMATION

KIT NO.	WEIGHT (lbs.)	DESCRIPTION	CaAc (Sq. Ft.)
KHB4-312-210-01	2150	3'-9" x 12' Bridge : Four 21' Columns	N/A

Connections 1 & 2

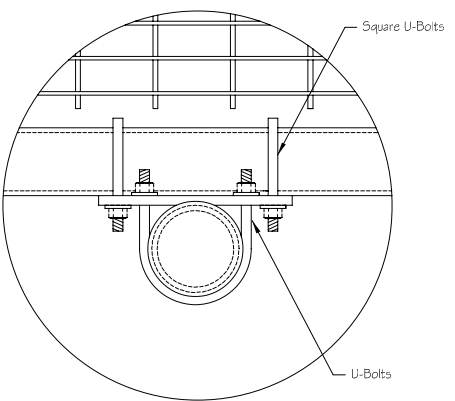

Foundation Detail

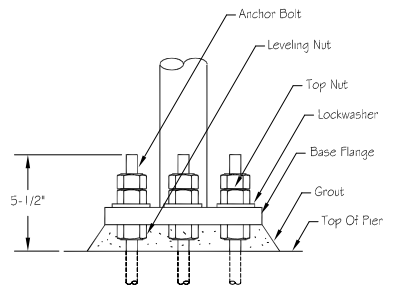
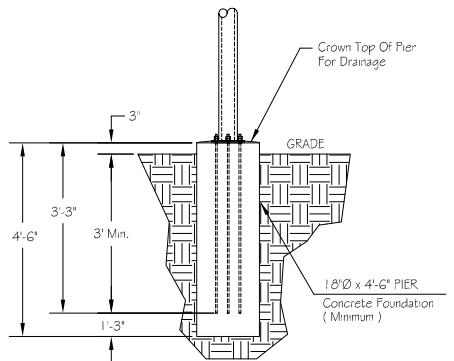

NOTES:

- 1.) Transmission Line Hangers Are Not Provided With This Kit !
- 2.) Steel Parts Indicated Above With An "*" Will Be Packed With The Hardware.
- 3.) The Foundation Design Provided Is Per Normal Soil Parameters Set Forth In TIA/EIA Standards. Bottom Of Foundation Must Be Extended Below The Frost Line For The Area In Which It Is To Be Installed. If Poor Soil Is Encountered, It Is Recommended That A Geotechnical Investigation Be Completed And Foundations Should Be Designed According To The Results & Recommendations Of The Geotechnical Report.

 PH# (812) 853-0595
 FAX# (812) 853-6652
 2855 HIGHWAY 261
 NEWBURGH, IN. 47630

REV. #	DESCRIPTION	DATE	APP.	DRAWN	DATE
				A.J.H.	2-11-02
				CHECK	DATE
				APPROVAL	DATE

THIRD ANGLE PROJECTION
 COMPANY CONFIDENTIAL INFORMATION CONTAINED HEREIN IS CONFIDENTIAL. IT IS TO BE USED SOLELY FOR THE PURPOSE PROVIDED, AND IT IS NOT TO BE DISCLOSED TO OTHERS WITHOUT THE PRIOR WRITTEN CONSENT OF TOWER INNOVATIONS.

TOLERANCES
 .X± 3/32" ANGLES± 2"
 .XX± 3/32" DRILLED HOLE± #1/32"
 .XXX± 1/16" BURNED HOLE± #1/16"

UNLESS OTHERWISE SPECIFIED DIMENSIONS ARE IN: INCHES

TITLE
3'-9" X 12' BRIDGE WITH FOUR 21' LENGTH PIPE COLUMNS

DWG NO.
KHB4-312-210-01

REV
 -

DO NOT SCALE DRAWING